

INOX



GENERALITÀ / FEATURES

Elettropompe autoadescante tipo jet, indicate per aspirazioni fino a 8/9 metri di profondità, specialmente in presenza di acque miscelate a gas. La pompa è integrabile con un box (Garden Inox) in materiale termoplastico e antiurto che ricopre completamente il motore e parte del corpo pompa.

Self-priming jet-type electric pumps, suitable for suction up to 8/9 meters, especially when water may be mixed with gas. It can be supplied with a thermoplastic crash-proof material box (upon request), fully covering the motor and partially the pump body.

MATERIALI / MATERIALS

- Corpo pompa: acciaio AISI 304
- Supporto: lega di alluminio
- Albero motore: acciaio inox AISI 416
- Girante: Noryl® o acciaio
- Tenuta meccanica in ceramica grafite

- *Pump body: stainless steel AISI 304*
- *Motor bracket: aluminium alloy*
- *Shaft: stainless steel AISI 416*
- *Impeller: Noryl® or stainless steel*
- *Ceramic graphite mechanical seal*

MOTORE / MOTOR

- Motore chiuso autoventilato
- Grado di protezione IP44
- Isolamento classe F
- Alimentazione monofase 230V-50Hz, con protezione termica
- Alimentazione trifase 230/400V-50Hz

- *Closed self-ventilated motor*
- *Protection: IP44*
- *Insulation class F*
- *Single-phase feeding 230V-50Hz, with thermal protection*
- *Three-phase feeding 230/400V-50Hz*

LIMITI DI IMPIEGO / OPERATING CONDITIONS

- Pressione massima d'esercizio: 6 bar
- Temperatura liquido pompato fino a 50°C

- *Max. working pressure: 6 bar*
- *Max. pumped liquid temperature: 50°C*

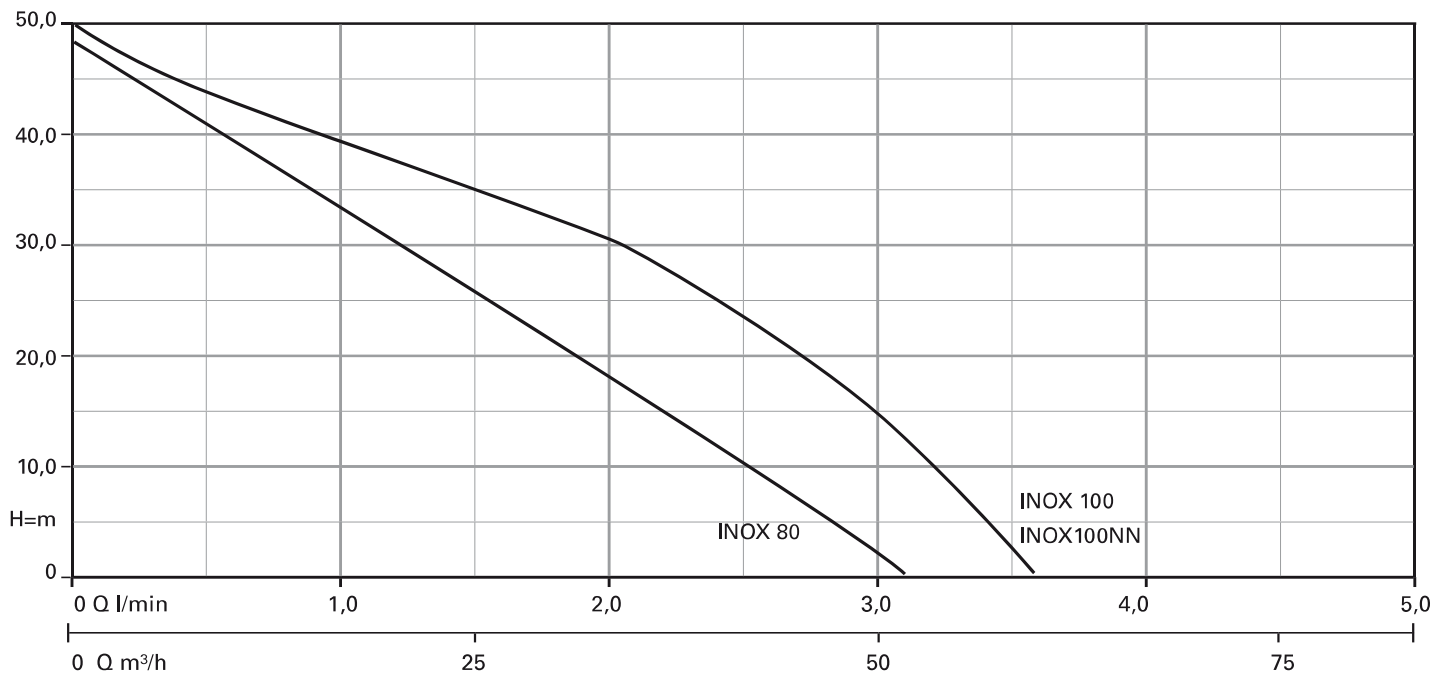

CARATTERISTICHE TECNICHE A 2900 GIRI / TECHNICAL PERFORMANCE AT 2900 RPM

Modello Model	P2		A	Q=Portata - Capacity				
	HP	kW		m³/h 0,6	1,2	1,8	2,4	3
1~			1x230V	l/min 10	20	30	40	50
Prevalenza manometrica totale in m C.A. Total head in meters w.c.								
INOX 80	0,8	0,59	3,7	38	34	29	25	18
INOX 100	1,0	0,75	4,6	43	38	32	26	15
INOX 100NN *	1,0	0,75	4,6	43	38	32	26	15

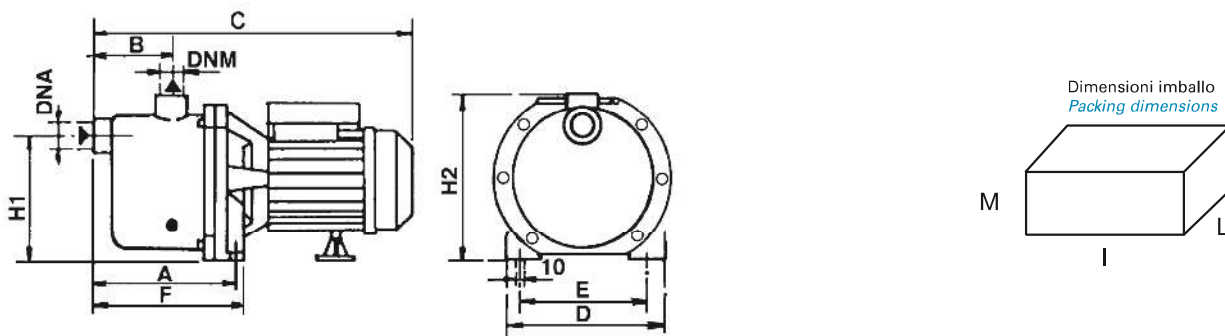

MODELLO POMPA PUMP'S MODEL	DIMENSIONI POMPA mm PUMP'S DIMENSIONS mm								DIMENSIONI IMBALLO mm PACKING DIMENSIONS mm			PESO WEIGHT kg
	A	B	C	D	E	H1	DNA	DNM	I	L	M	
INOX 80	163	72	320	162	126	150	1" G	1" G	350	176	200	7
INOX 100	165	79	365	175	140	150	1" G	1" G	400	200	233	12
INOX 100NN	163	81	370	176	140	149	1" G	1" G	410	211	230	11,5